



# DNH

HEAD OFFICE, NORWAY  
DNH AS

Phone..... + 47 35 98 56 00  
Fax..... + 47 35 98 56 10  
E-mail..... dnh@dnh.no  
Web-Site..... www.dnh.no

ENGLAND  
DNH WW Ltd  
Phone..... + 44 1908 275 000  
Fax..... + 44 1908 275 100  
E-mail..... dnh@dnh.co.uk

GERMANY  
DNH GmbH  
Phone... + 49 040 6569 30-0  
Fax..... + 49 040 6569 30-30  
E-mail..... dnh@dnh.de

USA  
DNH Speakers Inc  
Phone..... + 1 484 494 5790  
Fax..... + 1 484 494 5793  
E-mail..... dnh@dnhspeakers.com

## JBP-120EExeN

ISO 9001 CERTIFIED

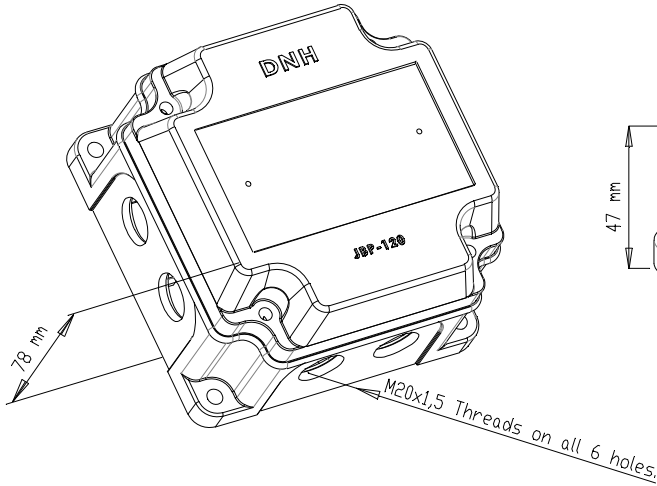

3 x M20 cable glands and  
4 x M20 blind plugs

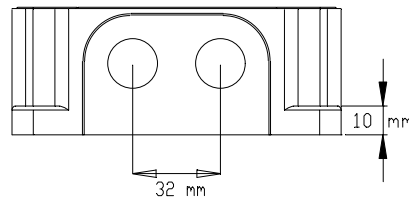
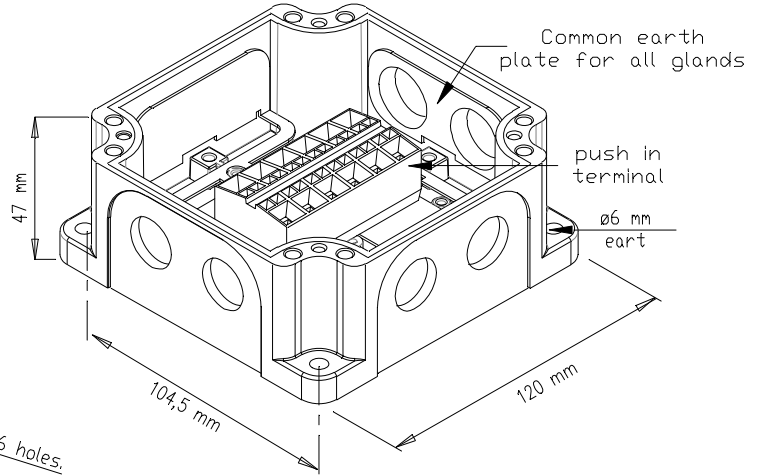

Certified by/ Certification code / Number : NEMKO / Ex e IIC T6 Gb/ 12ATEX1207X

| Specifications        |                                |
|-----------------------|--------------------------------|
| Material / Color      | Antistatic PA/ Black           |
| Mounting              | 4 screws                       |
| Termination           | Wago 264 terminal /earth plate |
| Weight                | 0,4 kg                         |
| IP-rating             | 67                             |
| Max. / min. amb. temp | -50°C ≤ Ta ≤ +50°C             |

### Installation, Operation and Maintenance Procedures

- Screw the box to the wall or ceiling with 2-4 screws.
- JBP-120 has six entries, and is delivered with three pieces M-20EExe ATEX cable glands and 4 pieces M-20EExe ATEX blind plugs.
- Fasten lid with four screws approximately 1 Nm.
- JBP-120EExeN is delivered with Wago terminal 264 with max 2,5 mm<sup>2</sup>.
- JBP-120EExeN has a two years warranty against defective workmanship.

DNH reserves the right to alter specifications without notice

